



---

# Author Guideline for Preparing a Paper for the International Journal of Technology Research and Management

First Author<sup>1</sup>, Second Author<sup>2</sup> and Third Author<sup>3</sup>  
University Department, University Name, Company City, State ZIP/Zone, Country<sup>1</sup>  
University Department, University Name, Company City, State ZIP/Zone, Country<sup>2</sup>  
University Department, University Name, Company City, State ZIP/Zone, Country<sup>3</sup>  
*Email address<sup>1</sup>, Email address<sup>2</sup>, Email address<sup>3</sup>*

---

**Abstract:** *The abstract should summarize the content of the paper. Try to keep the abstract below 150 words. Do not have references or displayed equations in the abstract. It is imperative that the margins and style described below be adhered to carefully. This will enable us to maintain uniformity in the final printed copies of the Journal. Papers not made according these guidelines will not be published although its content has been accepted for publication. Paper form is a necessary condition for its publication, as well as its content.*

**Keywords:** *Author Guide, Article, Camera-Ready Format, Paper Specifications, Paper Submission.*

---

## 1. Introduction

The text must be in English. Authors whose English language is not their own are certainly requested to have their manuscripts checked (or co-authored) by an English native speaker, for linguistic correctness before submission and in its final version, if changes had been made to the initial version. The submitted typeset scripts of each contribution must be in their final form and of good appearance because they will be printed directly. The document you are reading is written in the format that should be used in your paper.

This document is set in 10-point Times New Roman. If absolutely necessary, we suggest the use of condensed line spacing rather than smaller point sizes. Some technical formatting software print mathematical formulas in italic type, with subscripts and superscripts in a slightly smaller font size. This is acceptable.

## 2. Headings and Footnotes

Major headings are to be column centered in a bold font without underline. They need be numbered. "2. Headings

and Footnotes" at the top of this paragraph is a major heading.

### 2.1 Subheadings

Subheadings should be as the above heading "2.1 Subheadings". They should start at the left-hand margin on a separate line.

The top of this paragraph illustrates a sub-subheading.

**Title:** The title should be centered across the top of the first page and should have a distinctive font of 18 points Century. It should be in a bold font and in lower case with initial capitals.

**Authors' Names and Addresses:** The authors' names and addresses should be centered below the title. These lines should be 9 points Times New Roman.

**Keywords:** From 4 to 6 keywords should follow the abstract (as a subheading: *Key words*, of the Abstract).

**Illustrations or pictures:** All halftone illustrations or pictures can be black and white and/or colored. Supply the best quality illustrations or pictures possible.

## 2.1 Footnotes

Footnotes should be typed in singled-line spacing at the bottom of the page and column where it is cited. Footnotes should be rare.

## 3. Tables, Figures and Equations

### 3.1 Tables and Figures

To insert “Tables” or “Figures”, please paste the data as stated below. All tables and figures must be given sequential numbers (1, 2, 3, etc.) and have a caption placed below the figure (“Fig Caption”) or above the table (“Fig Table”) being described, using 8pt font and please make use of the specified style “caption” from the drop-down menu of style categories

Table 1: Margin specifications

<i>Margin</i>	<i>A4 Paper</i>	US Letter Paper
Left	18.5 mm	14.5 mm (0.58 in)
Right	18mm	13 mm (0.51 in)

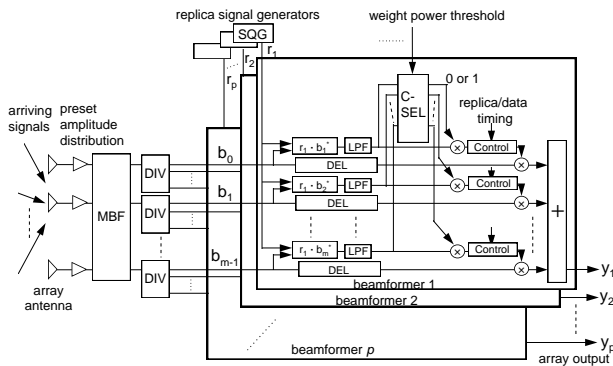

Fig. 1 Proposed beam former.

### 3.2 Equations

They should be numbered consecutively throughout the text. Equation numbers should be enclosed in parentheses and flushed right. Equations should be referred to as Eq. (X) in the text where X is the equation number. In multiple-line equations, the number should be given on the last line.

$$y_i(N) = \sum_{n=0}^{m-1} w_n(N) b_n(N)$$

$$= \sum_{n=0}^{m-1} b_n^*(N) r_i(N) \cdot b_n(N) \quad (1)$$

## 4. Conclusions

The better your paper looks, the better the Journal looks. Thanks for your cooperation and contribution.

## Appendix

Appendices, if needed, appear before the acknowledgment.

## Acknowledgments

Insert acknowledgment, if any. The preferred spelling of the word “acknowledgment” in American English is without an “e” after the “g.” Use the singular heading even if you have many acknowledgments. Avoid expressions such as “One of us (S.B.A.) would like to thank ....” Instead, write “F. A. Author thanks ... .” Sponsor and financial support acknowledgments are also placed here.

## References

- [1] A. A. Name, and B. B. Name, Book Title, Place: Press, Year.
- [2] A. Name, and B. Name, "Journal Paper Title", Journal Name, Vol. X, No. X, Year, pp. xxx-xxx.
- [3] A. Name, "Dissertation Title", M.S.(or Ph.D.) thesis, Department, University, City, Country, Year.
- [4] A. A. Name, "Conference Paper Title", in Conference Name, Year, Vol. x, pp. xxx-xxx.